

PORTE ESTERNE - PUERTAS ESTERIORES OUTER DOORS - AUSSENTÜREN

ATTENZIONE: Per installazioni in condizioni ambientali e climatiche particolari (es. umide, acide, saline), consultare prima l'ufficio commerciale - ADVERTENCIA: para su instalación en particular clima o ambiente (por ejemplo - húmedo, ácido, ambiente salino) consulte a la oficina de ventas - CAUTION: For installations in particular environments or climate (ex. wet, acid, saline) consult sales office first - ACHTUNG: Bei Installationen in Sonderumfeldern oder -klima (z.B.: nass, saure, salzig) wenden Sie sich vorher an der Verkaufsbteilung

835E 10

Biloba
EVO frame

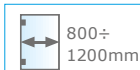
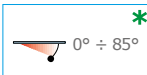

• Cerniera oleodinamica vetro-muro per porte in battuta, con velocità di chiusura regolabile e controllo costante di frenatura; permette un'apertura della porta fino a 180°. Stop a +90° +180°. **Si installa su porte con profilo in battuta. Profondità stipite da 30 a 50 mm.**

• Bisagra automática hidráulica vidrio-pared para puerta con tope; regulación de velocidad de cierre de la puerta y control constante de frenado; la puerta se puede abrir hasta 180°. Stop a +90° +180°. **Se instala en puertas con perfil con batida. Profundidad estípite entre 30 y 50 mm.**

• Hydraulic hinge glass to wall for doors with stop, with adjustable closing speed and constant braking control; the door opens up to 180°. Stop at +90° +180°. **Installed on doors with a profile on a stop. Jamb depth from 30 to 50 mm.**

• Hydraulikband Glas-Wand für Anschlagtüren, mit regulierbarer Schließgeschwindigkeit und konstanter Kontrolle der Bremsung; Öffnung der Tür bis 180°. Feststellung +90° +180°. **Man kann es auf Türen mit Rahmen benutzen. Pfostentiefe von 30 bis 50 mm.**

835E10 R = destra - derecha - right - rechts

835E10 L = sinistra - izquierda - left - links

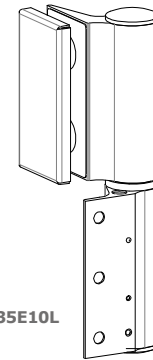

*

• È necessaria una battuta in chiusura in quanto la cerniera ha una precarica. • Necesita de un cierre con tope, puesto que la bisagra tiene una precarga. • The hinge has a preloading, therefore a closing with a stop is necessary. • Eine Schließfeststellung ist notwendig, weil das Scharnier eine mechanische Belastung hat.

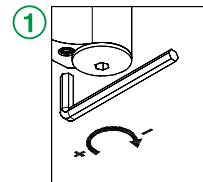
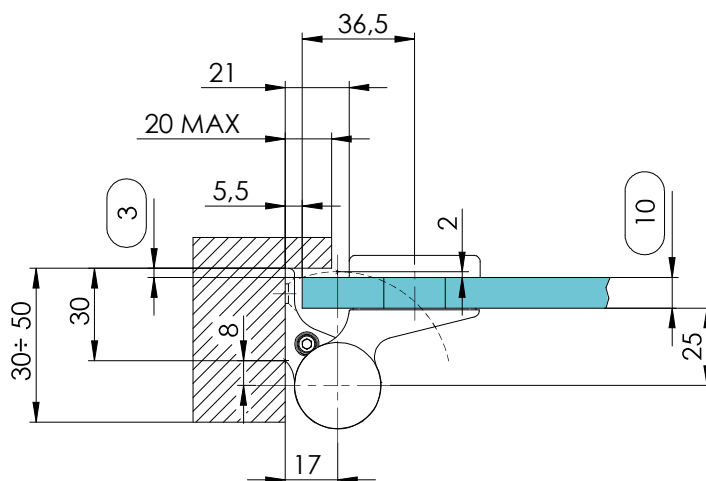
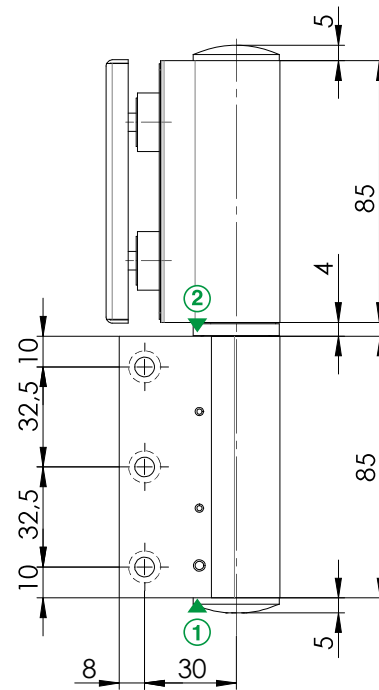
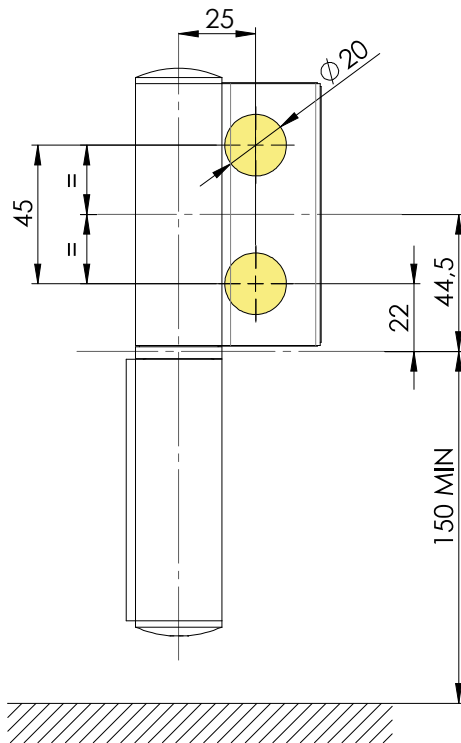

Regolazione della velocità di chiusura con scatto finale
Ajuste de la velocidad de cierre con clic final
Closing speed adjustment with final latch
Regulierung der Schließgeschwindigkeit mit Endschwung

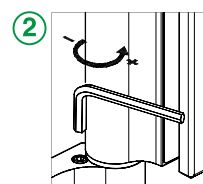

Regolazione della velocità di chiusura senza scatto finale
Ajuste de la velocidad de cierre sin clic final
Closing speed adjustment without final latch
Regulierung der Schließgeschwindigkeit ohne Endschwung